



---

# ***CANNABIS PACKAGING EQUIPMENT***

---



[WWW.DURA-PACK.COM](http://WWW.DURA-PACK.COM)



[SALES@DURA-PACK.COM](mailto:SALES@DURA-PACK.COM)



313.299.9600

7641 HOLLAND ROAD | TAYLOR, MICHIGAN 48180

# ***DL-135 - CBD, GUMMIES, EDIBLES AUTOMATED VIBRATORY WEIGHING, FILLING & PACKAGING MACHINE***



- ✦ 100% Non-proprietary control system
- ✦ AI powered dosing intelligently learns and understands your product
- ✦ Tool-less disassembly in under 30 seconds
- ✦ 6" user-friendly touchscreen
- ✦ Speed: Up to 30 bags/minute
- ✦ Heavy-duty 304 stainless steel construction  
Capacity (Weight/Volume): 1kg
- ✦ Industry-leading scale resolution
- ✦ All electric - no compressed air required
- ✦ Simple plug-and-play interface to auxiliary equipment
- ✦ Capacity (Weight/Volume): 5kg /5 Liter
- ✦ Scale Resolution: 0.2g Accuracy: 2% or better
- ✦ Speed: Up to 12 cycles/min  
Thermal embosser
- ✦ Power: 120/240 VAC, 1PH, 60HZ

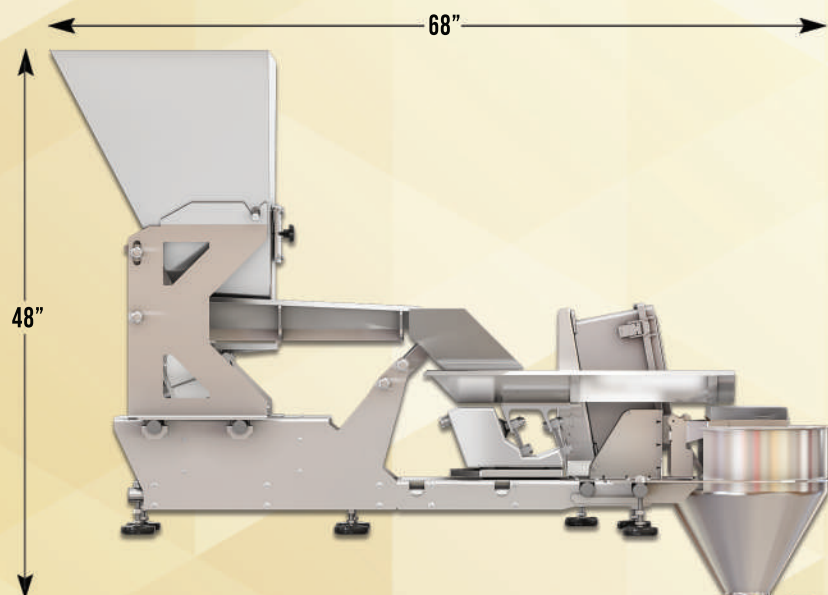
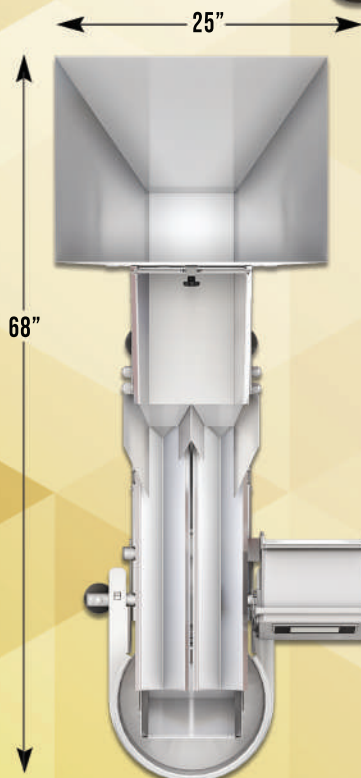

[WWW.DURA-PACK.COM](http://WWW.DURA-PACK.COM)



[SALES@DURA-PACK.COM](mailto:SALES@DURA-PACK.COM)



313.299.9600

7641 HOLLAND ROAD | TAYLOR, MICHIGAN 48180





# CANNABIS PACKAGING WEIGHING & FILLING SYSTEM

The cannabis packaging system enables organizations to scale their cannabis packaging operations and package cannabis 3-4 times faster than hand packing. With the integrated high-performance multi-head combination scale, fragile flower handing design and an industry-leading scale accuracy of 0.01g, the Dura-Pack low profile cannabis packaging system ensures that your cannabis products will be packaged efficiently, accurately and will dramatically increase your cannabis packaging production.



- \* 14 Individual weigh heads offer optimum speeds and weighing accuracy at low target weights.
- \* Scale resolution: 0.02g
- \* Set target weights with 0.01g accuracy (E.g. 1.00g, 3.50g, 7.00g & 28.35g)
- \* Store up to 300 programs for easy product transitions
- \* Weigher speed capable of 160 weighments per minute
- \* Capable of withstanding up to 150kg Weigh Flower up to 50mm in length
- \* Stainless steel product surfaces with tool-less bucket, feed pan and chute removal for easy cleaning
- \* 10.4 inch color touch screen with built-in printer
- \* AC 230V (+10%~-15%), 60 Hz, Single Phase 1.0kVA

**STOP LEAVING MONEY ON THE  
PRODUCTION FLOOR!**

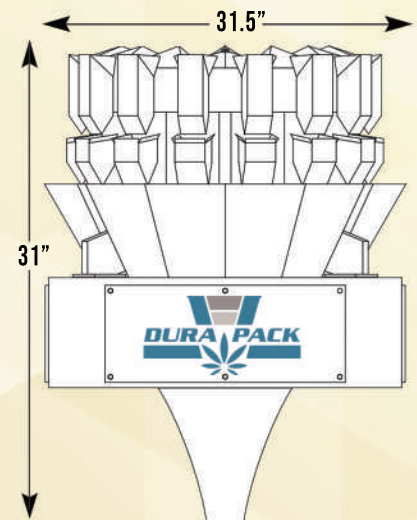
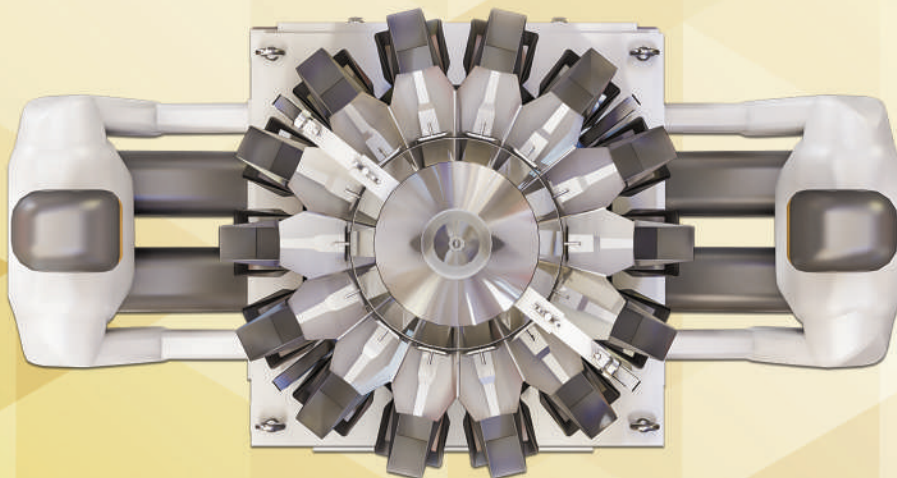

[WWW.DURA-PACK.COM](http://WWW.DURA-PACK.COM)



[SALES@DURA-PACK.COM](mailto:SALES@DURA-PACK.COM)



313.299.9600

7641 HOLLAND ROAD | TAYLOR, MICHIGAN 48180





# AUTOMATED CANNABIS DUAL BAGGING PRE-MADE POUCH SYSTEM



- ✦ Supports large bag sizes and varieties
- ✦ Industry-leading change-over time
- ✦ Intelligent 3D alarm system
- ✦ All off-the-shelf components
- ✦ Heavy-duty 304 stainless steel construction
- ✦ Custom configuration available
- ✦ Allen-Bradley PLC with ethernet
- ✦ Speed: Up to 30 bags/minute
- ✦ Bag Sizes: 4"Wx6"L – 12"Wx18"L
- ✦ Capacity (Weight/Volume): 1kg
- ✦ Air: 80psi @ 20CFM
- ✦ Power: 120/240 VAC. 1PH. 60Hz, 20A
- ✦ Dimpled contact surface
- ✦ Non-stick coatings
- ✦ Level sensing
- ✦ Gas flush
- ✦ Ink jet
- ✦ Thermal embosser
- ✦ Washdown
- ✦ Take-away conveyor
- ✦ High dust/powder tooling

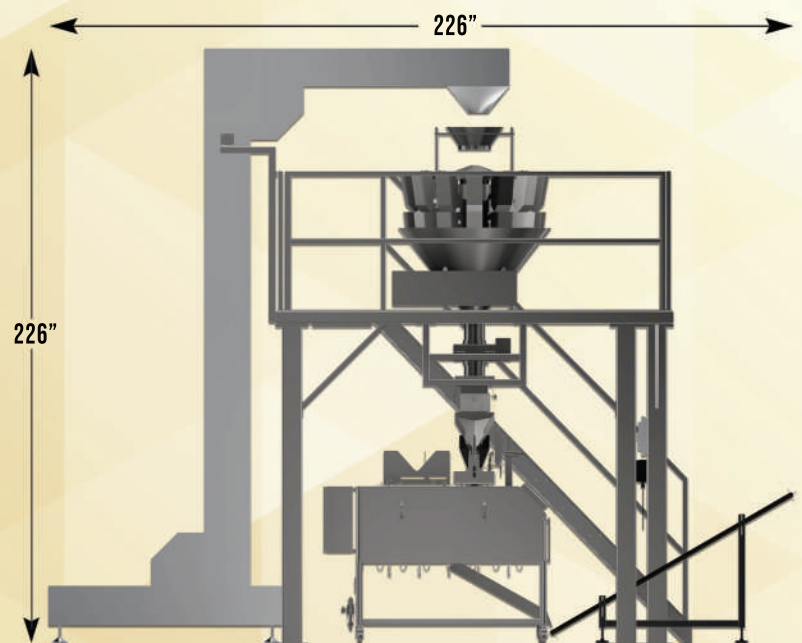
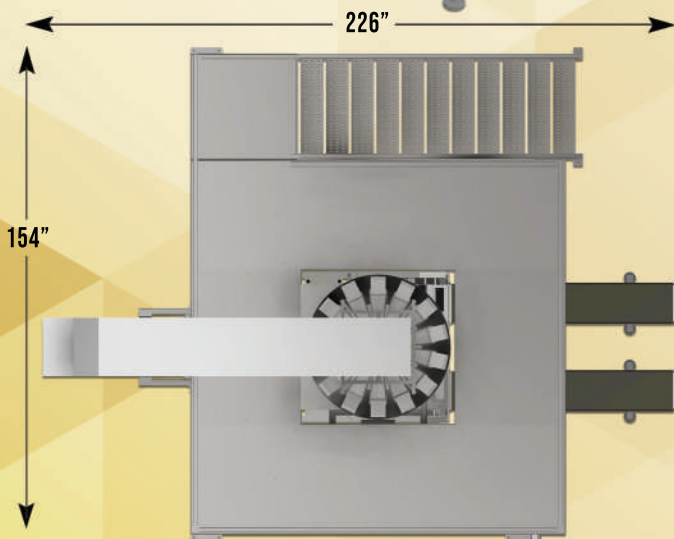

[WWW.DURA-PACK.COM](http://WWW.DURA-PACK.COM)



[SALES@DURA-PACK.COM](mailto:SALES@DURA-PACK.COM)



313.299.9600

7641 HOLLAND ROAD | TAYLOR, MICHIGAN 48180

